



Model: 8035E-500, 1035E-500, 1235AC-500, 1050E-500 Serial #: ALL	Oct. 23, 2014
Product Bulletin # TDS-142	

Proper Adjustment of the Handler Lock Sensor

On 350- and 500-ton top drives with 5:1 gear ratios (due to manufacturing variances) the dimension given in the parts manual for setting up the handler lock sensor may not be accurate. Instructions for properly setting up and testing the handler lock sensor are given below.

Adjusting the Handler Lock Sensor

1. Position the sensor such that there is a 0.12 in. gap between the sensor and the side of the lock pin.
2. Hold the sensor in place and tighten the jam nut.
3. Position the sensor bracket so there is 0.63 in. between the center of the sensor and the top of the lock pin when the cylinder is fully extended, or a gap of at least 0.25 in. between the bottom of the sensor and the top of the pin, as shown in Figure 1 on page 2.

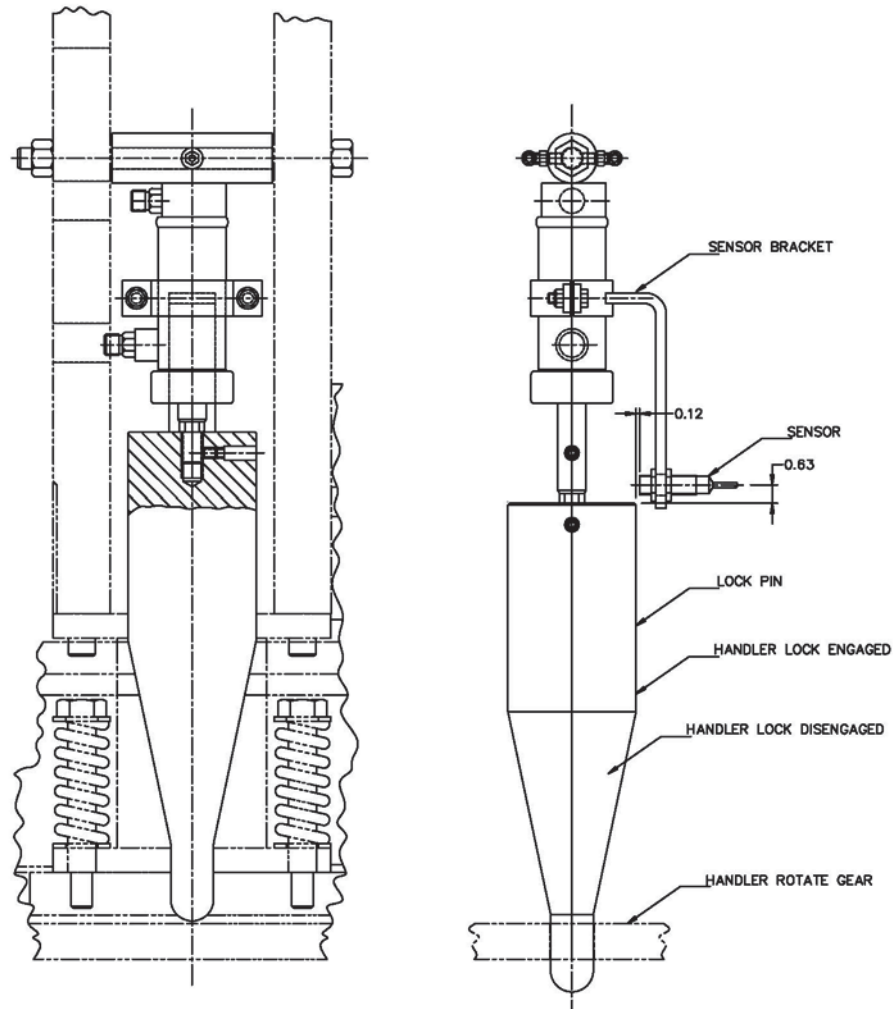

Figure 1: Adjusting the handler lock sensor.

4. Tighten the sensor bracket bolts to lock the position of the sensor.
5. Verify the sensor is still 0.12 in. away from the side of lock pin and 0.63 in. above the top of the lock pin, as shown in Figure 1 on page 2.

Testing the Handler Lock Sensor

1. On the console, activate the handler unlock command.
2. Visually inspect the lock pin. Ensure the pin is in the up position and the cylinder is retracted clear of the handler rotate gear, as shown in Figure 2.

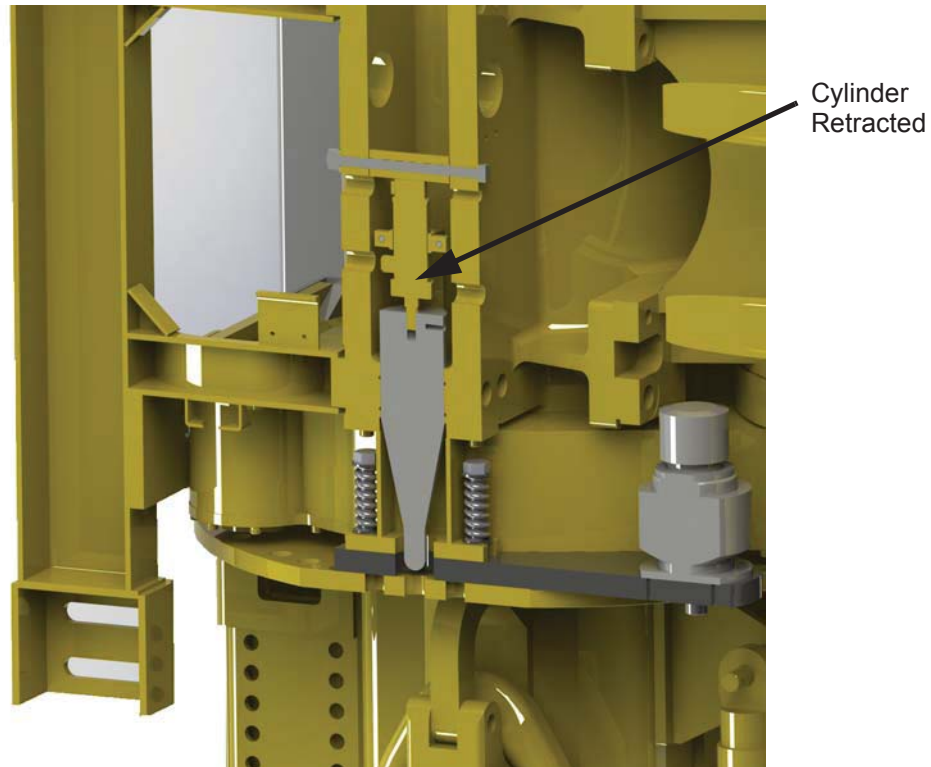

Figure 2: Cylinder retracted.

3. Ensure the input for the handler lock sensor is ON.
4. On the console, activate the handler lock command.

5. Visually inspect the handler lock pin. Ensure the pin is fully locked; the sensor should be visible and cleared of the lock pin, as shown in Figure 3.

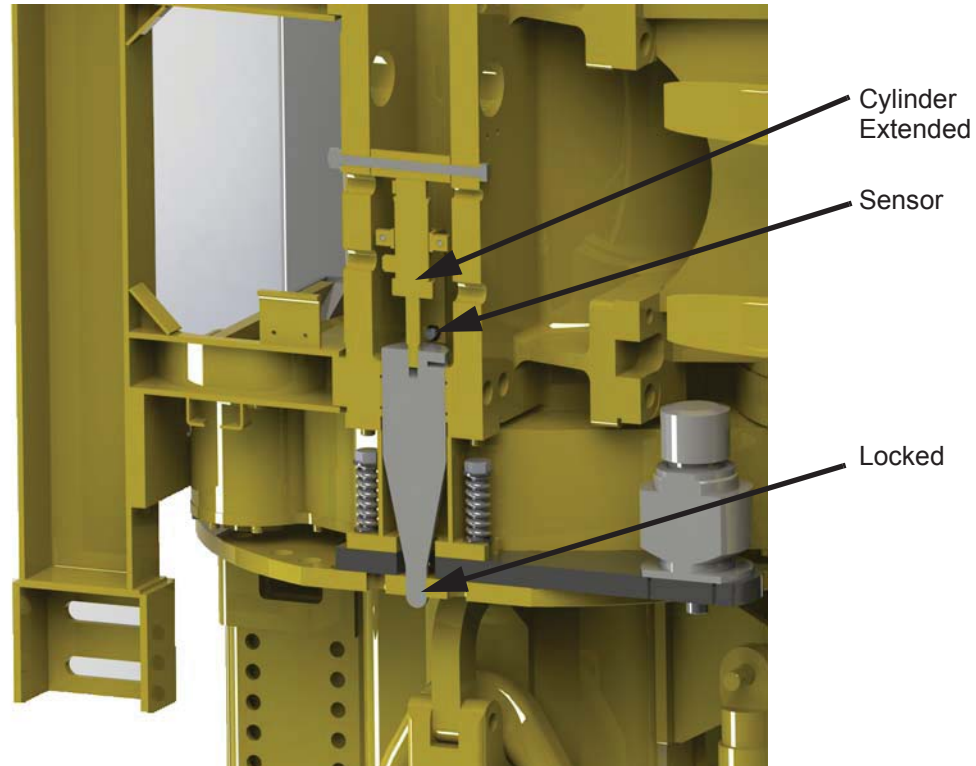

Figure 3: Cylinder extended.

6. Unlock the handler. Ensure the input for the handler lock sensor is OFF.
7. Rotate the handler so the lock pin is between locking holes. Activate the handler lock command, and verify an alarm occurs.
8. Repeat steps 1–7 at least three times to ensure the sensor is working properly.
9. Rotate the handler until the pin is over a lock hole. Activate the handler lock and verify all safe.